



# UC50e

High Temp Undercounter  
Dishwasher And  
Glasswasher



### FEATURES:

- **Energy Star Qualified.**
- 30 racks / 120 covers per hour.
- Fully automatic cycle for easy operation
- Built-in detergent and rinse chemical pumps.
- Pump drain allows for multiple installation applications including elevated drains.
- Safety Temp feature assures 180°F sanitizing rinse every cycle.
- Built-in 6 kW booster heater
- 2.7 kW wash tank heater.
- Double skin stainless steel provides consistent heating and a quiet operation.
- Low 0.8 US gal. water usage per rack.
- Door and water level safety switches, plus booster safety thermostat.
- Stainless steel safety filters protect wash pump.
- Polished stainless steel surface and tanks with rounded corners for a total and easy cleaning.
- Operator friendly, removable wash and rinse arms allows for easy cleaning.
- Triple filtering protection system, captures excess soil and debris.

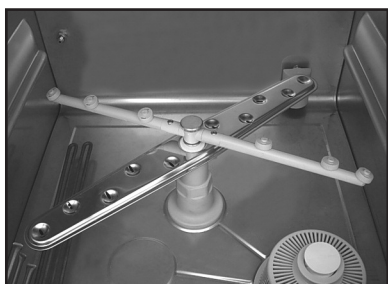

Upper and lower wash and rinse arms guarantee excellent results.



Large 13" maximum loading height door clearance accommodates oversized plates, glasses and utensils.



Built-in detergent and rinse chemical pumps.



Top mounted controls are easy to read and simple to operate.

**CMA  
MIZER®**  
Registered Trademark





# UC50e

High Temp Undercounter Dishwasher And Glasswasher

**WARNINGS:**

- Plumbing connections must be made by a qualified service company who will comply with all available Federal, State, and Local Health, Plumbing and Safety codes.
- CMA recommends utilizing a water softening system to maintain water hardness measurements of 3.5 gpg (grains per gallon) or less. This will assure maximum results and optimum operation of the dishwasher.

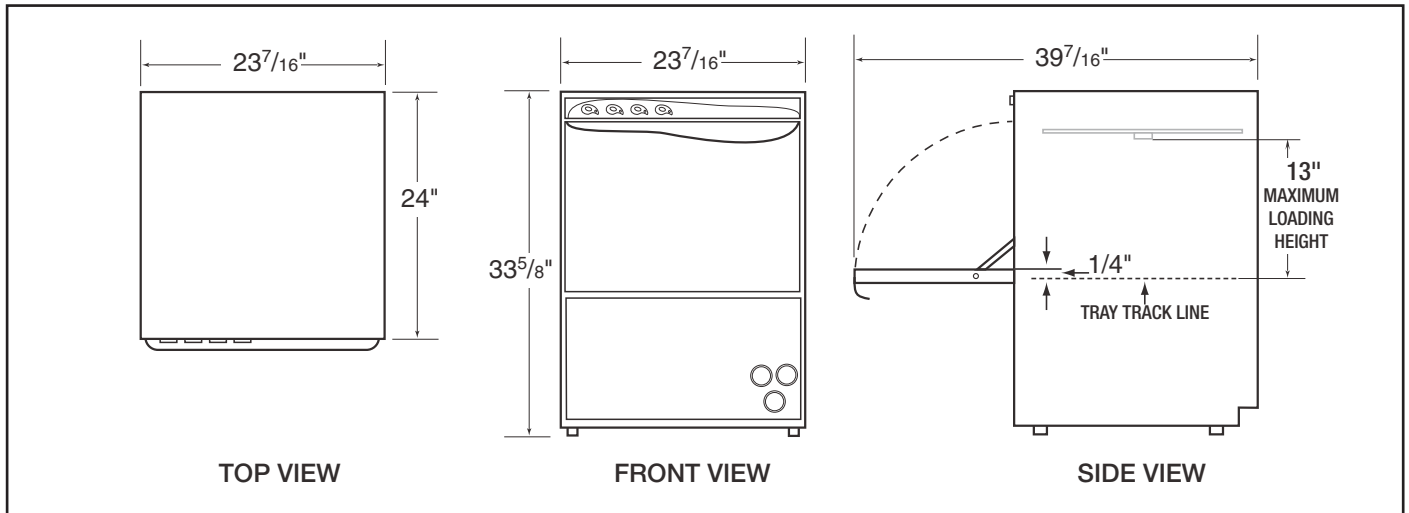

**Specifications:**

| MODEL UC50e                                     | USA             | METRIC                | USA         | METRIC |
|---|-----------------|-----------------------|-------------|--------|
| <b>WATER CONSUMPTION</b>                        |                 |                       |             |        |
| PER RACK  | .8 GAL          | (3L)                  |             |        |
| PER HOUR  | 24/16 GAL       | (90/60L)              |             |        |
| <b>OPERATING CYCLE</b>                          |                 |                       |             |        |
| WASH TIME-SEC                                   | 100/160         | 100/160               |             |        |
| RINSE TIME-SEC                                  | 15/15           | 15/15                 |             |        |
| DWELL-SEC                                       | 5/5             | 5/5                   |             |        |
| TOTAL CYCLE-SEC                                 | 120/180         | 120/180               |             |        |
| <b>OPERATING CAPACITY</b>                       |                 |                       |             |        |
| RACKS PER HOUR                                  | 30/20           | 30/20                 |             |        |
| WASH TANK CAPCITY                               | 6.87 GAL        | (26L)                 |             |        |
| <b>WATER REQUIRMENTS</b>                        |                 |                       |             |        |
| WATER INLET                                     | 1/4"            | (6.35mm)              |             |        |
| DRAIN CONNECTION                                | 1"              | (25.4mm)              |             |        |
| RINSE PRESSURE SET                              | 24 PSI          | 1.7kg/cm <sup>2</sup> |             |        |
| <b>CYCLE TEMPERATURES</b>                       |                 |                       |             |        |
| WASH-°F   | 155°F-160°F     | (68°C/71°C)           |             |        |
| RINSE-°F  | 180°F-195°F     | (82°C/90°C)           |             |        |
| <b>FRAME DIMENSIONS</b>                         |                 |                       |             |        |
| DEPTH   | 24"             | (61 CM)               |             |        |
| WIDTH   | 23-7/16"        | (59.5 CM)             |             |        |
| HEIGHT  | 33-5/16"        | (84.5 CM)             |             |        |
| MAXIMUM LOADING HEIGHT                          | 13"             | (33 CM)               |             |        |
| <b>STANDARD DISHRACK DIMENSIONS</b>             | 1               | 1                     |             |        |
|   | 19-3/4"X19-3/4" | (50X50CM)             |             |        |
| <b>SHIPPING WEIGHT</b>                          | 165#            | 75(KG)                |             |        |
| <b>WASH PUMP MOTORS HP</b>                      | 3/4HP           |                       |             |        |
| <b>HEATERS</b>                                  |                 |                       |             |        |
| WASH TEMP HEATER                                | 2.7kW / 2.94kW  |                       |             |        |
| BOOSTER HEATER                                  | 6kW / 6.53kW    |                       |             |        |
| <b>ELECTRICAL RATING (TOTAL AMPERAGE DRAWN)</b> | <b>VOLTS</b>    | <b>PHASE</b>          | <b>AMPS</b> |        |
|   | 208             | 1                     | 28          |        |
|   | 230             | 1                     | 30          |        |

**Summary Specifications:**

The UC50e dishwasher and glasswasher is a front loading machine designed to produce sparkling clean glasses and dishes. Constructed of double walled stainless steel skin providing constant heating and a quiet operation. Standard features include upper and lower wash/rinse arms and wash and booster tank heater. Features include 13" maximum loading height, standard liquid detergent rinse-aid dispenser.

**KROMO BRANDS**  
Distributed exclusively by CMA Dishmachines

**Advisory:** CMA does NOT endorse "Tankless On-Demand" water heaters for use on CMA Dishmachine products. CMA DOES endorse, and highly recommends, the standard "tank" style water heaters, sized properly to handle each particular facility with their water heating requirements.



CMA Dishmachines 12700 Knott Street Garden Grove, CA 92841 • 800-854-6417 • 714-898-8781 • Fax: 714-895-2141 • www.cmadishmachines.com

CMA reserves the right to modify specifications or discontinue models without prior notification.

PN: 10900.00

© 11-2016 CMA, Inc.

an Ali Group Company



The Spirit of Excellence